

Cutlass Fasteners, Inc.

83 Vermont Ave., Unit 6, Warwick, RI 02888
 Tel: (401) 732-6333 Fax: (401) 732-6336
 cutlass-studwelding.com

Stud Welding...

- Fasteners
- Equipment
- Service

CD NON-FLANGED WELD STUDS

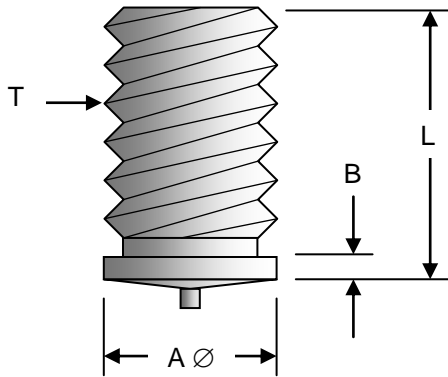

T (Thread)	A Ø	B
4-40	0.114	0.030
6-32	0.140	0.030
8-32	0.166	0.030
10-24 & 10-32	0.192	0.030
1/4-20	0.252	0.030
5/16-18	0.315	0.040
3/8-16	0.380	0.040

Thread Size	Material	Part No. Prefix	L (Length ± 0.015")													
			1/4	3/8	1/2	5/8	3/4	7/8	1.0	1.1/4	1.1/2	1.3/4	2.0	2.1/4	2.1/2	3.0
4.40 UNC	Mild Steel	2501-														
	Stainless	2502-	0208	0212	0216	0220	0224	0228	0232	0240	0248	0256	0264	0272	0280	0296
	Aluminum	2503-														
6-32 UNC	Mild Steel	2501-														
	Stainless	2502-	0308	0312	0316	0320	0324	0328	0332	0340	0348	0356	0364	0372	0380	0396
	Aluminum	2503-														
8-32 UNC	Mild Steel	2501-														
	Stainless	2502-	0408	0412	0416	0420	0424	0428	0432	0440	0448	0456	0464	0472	0480	0496
	Aluminum	2503-														
10-32 UNF	Mild Steel	2511-														
	Stainless	2512-	0508	0512	0516	0520	0524	0528	0532	0540	0548	0556	0564	0572	0850	0596
	Aluminum	2513-														
10-24 UNC	Mild Steel	2501-														
	Stainless	2502-	0508	0512	0516	0520	0524	0528	0532	0540	0548	0556	0564	0572	0850	0596
	Aluminum	2503-														
1/4-20 UNC	Mild Steel	2501-														
	Stainless	2502-	0808	0812	0816	0820	0824	0828	0832	0840	0848	0856	0864	0872	0880	0896
	Aluminum	2503-														
5/16-18 UNC	Mild Steel	2501-														
	Stainless	2502-	1008	1012	1016	1020	1024	1028	1032	1040	1048	1056	1064	1072	1080	1096
	Aluminum	2503-														
3/8-16 UNC	Mild Steel	2501-														
	Stainless	2502-	1208	1212	1216	1220	1224	1228	1232	1240	1248	1256	1264	1272	1280	1296
	Aluminum	2503-														

Stock Sizes

Part No. example....10-24UNC x 3/8" long Mild Steel....2501-0512

email: sales@cutlass-studwelding.com