

Cutlass Fasteners, Inc.

83 Vermont Ave., Unit 6, Warwick, RI 02888
 Tel: (401) 732-6333 Fax: (401) 732-6336
 cutlass-studwelding.com

Stud Welding...

- Fasteners
- Equipment
- Service

CLIPPER PARTS LIST

CLIPPER 8 PARTS LIST

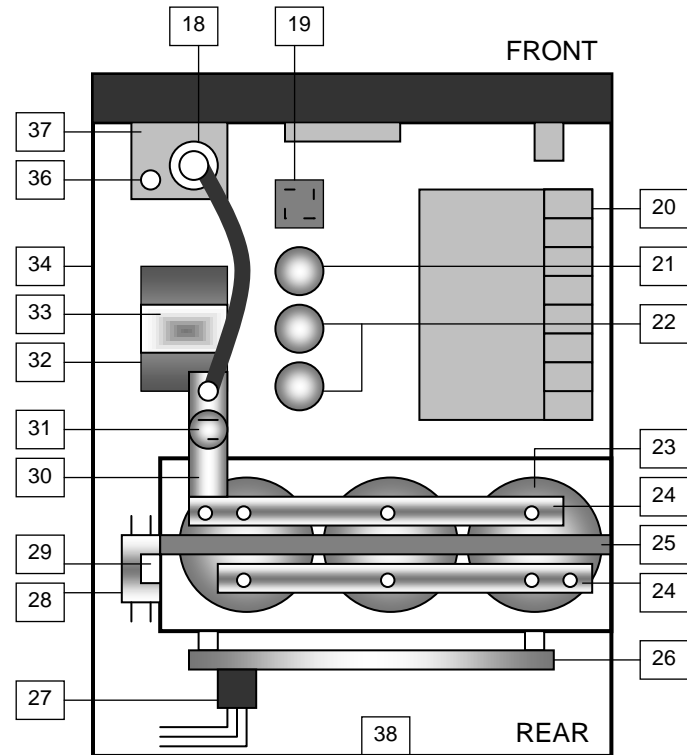
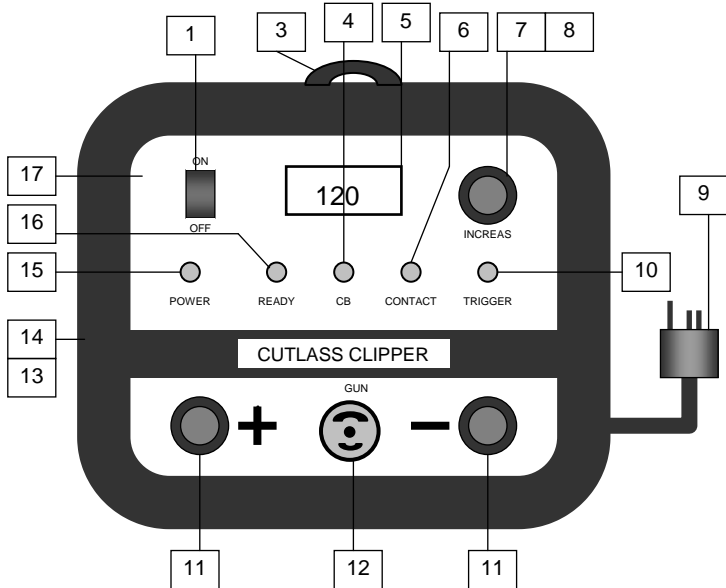

ITEM	DESCRIPTION	PART NO.
1	ON/OFF SWITCH	018-862
3	CARRYING HANDLE	602-1163
4	CIRCUIT BREAKER	999-071
5	VOLTMETER	999-110
6	CONTACT LIGHT	602-1196
7	POTENTIOMETER	001-031
8	POTENTIOMETER KNOB	600-657
9	POWER CABLE	999-090
10	TRIGGER LIGHT	602-1196
11	WELD SOCKET P/M	000-577
12	CONTROL SOCKET P/M	000-598P
13	OUTER COVER	901-046
14	PANEL TRIM	602-318A
15	POWER LIGHT	602-1194
16	READY LIGHT	602-1195
17	FRONT FACIA DECAL	602-318A
18	WELD SCR	602-212
19	BRIDGE RECTIFIER	019-592
20	MAIN TRANSFORMER	602-1268
21	DISCHARGE RESISTOR	002-984
22	CHARGE RESISTOR	011-494
23	CAPACITOR 22,000MFD	602-2299
24	STANDARD BUSS BAR	018-838
25	CAPACITOR CLAMP	602-1869
26	PC BOARD	602-1212
27	WIRE HARNESS	602-1213
28	MAINS FILTER	602-1065
29	WIRE CLIP	602-1272
30	NEGATIVE BUSS BAR	602-1899
31	CHARGE SCR	003-461
32	RELAY BASE	602-250
33	RELAY 120VOLT	602-249
34	CHASSIS	901-044
36	INSULATOR STANDOFF	901-064
37	HEATSINK PLATE	602-1187
38	REAR PANEL	901-045

* SEE NEXT PAGE FOR CLIPPER "10" PARTS.

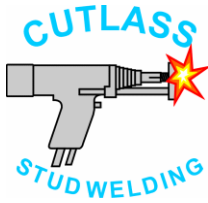

Cutlass Fasteners, Inc.

83 Vermont Ave., Unit 6, Warwick, RI 02888
Tel: (401) 732-6333 Fax: (401) 732-6336
cutlass-studwelding.com

Stud Welding...

- Fasteners
- Equipment
- Service

CLIPPER PARTS LIST

CLIPPER 10 PARTS LIST

All parts used are the same as the Clipper 8 except the following:

PKM-1B WELD GUN

ITEM	DESCRIPTION	PART NO.
27	#2 WELD CABLE	602-078

CLIPPER 10 CONTROLLER

ITEM	DESCRIPTION	PART NO.
13	OUTER COVER	901-048
30	NEGATIVE BUSS BAR	602-1904
34	CHASSIS	901-047
39*	POSITIVE BUSS BAR	602-1496

* NOT SHOWN